

# Noncontact Sensing of Electrocardiographic Potential and Body Proximity by In-bed Conductive Fabrics

Kei Ito<sup>1</sup>, Yutaka Fukuoka<sup>2</sup>, Gert Cauwenberghs<sup>3</sup>, Akinori Ueno<sup>1</sup>

<sup>1</sup>Tokyo Denki University, Tokyo, Japan

<sup>2</sup>Kogakuin University, Tokyo, Japan

<sup>3</sup>University of California San Diego, CA, USA

## Abstract

*Aging populations call for pervasive monitoring of activity of elderly patients and their electrocardiographic potential (ECG) in the hospital or at home. In this study, we propose a noncontact approach for continuous sensing of presence, position and ECG of a human body on a bed. Six pieces of belt-like conductive fabrics were used as sensing electrodes. Three of the pieces were connected to a newly developed ECG amplifier featuring ultra-high input impedance. The other three pieces were connected to two sets of capacitance meters. Capacitances for upper and lower bodies were separately measured. A male volunteer subject was instructed to sit down on a bed, lie on the bed in a supine position, and change to a lateral position at fixed time intervals.*

*In result, the combination of two voltages, inversely proportional to the upper and lower body coupling capacitances, varied in accordance with the change in the subject's position. In addition ECG was detected in the periods when the subject was in supine or lateral position. And distinct QRS complexes and T-waves were confirmed, though some distortion can be observed. These results demonstrate the potential of the proposed approach for noncontact sensing of ECG and lying body capacitance toward awareness-free pervasive and continuous monitoring.*

## 1. Introduction

Populations in developed countries are aging and are predicted to continue aging [1]. The aging populations call for pervasive monitoring of vital signals of elderly patients and their activity in the hospital or at home. For instance, electrocardiographic potential (ECG) of the patients will be beneficial for detecting abnormal cardiac activity. Absence or presence of the patients' body on the bed during night time may imply wandering or nocturia symptoms. Furthermore, combination of these signals can provide more reliable alarm for critical situations such as

asystole on the bed.

For the monitoring purpose at home, noncontact unobtrusive approach is essential for gaining broad acceptance and prolonged daily use. In recent, some noncontact methods for obtaining ECG were proposed [2], and Ueno et al. proposed a capacitive sensing method employing in-bed conductive fabrics [3,4]. Since this method will become more effective when paired with body proximity sensors, we propose an extended noncontact approach for continuous sensing of presence, position and ECG of a human body on a bed.

## 2. Materials and methods

Outline of the proposed measurement system is shown in Figure 1. Six pieces of belt-like conductive fabrics (Kitagawa Industries, CSTK) were used as sensing electrodes. All electrodes are placed on a mattress and covered with a cotton bed sheet of 300 $\mu$ m thick. Three of the pieces were connected to a unit of body proximity measurement, and proximities of upper and lower bodies to the electrodes are measured respectively in the unit. The other three pieces were connected to an ECG measurement unit.

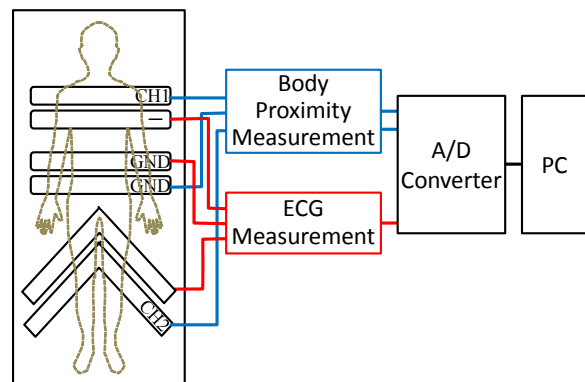
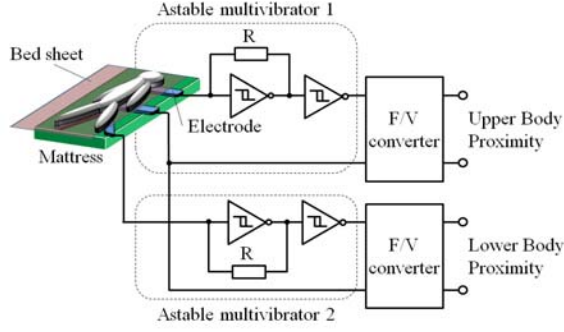
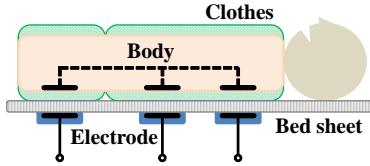

Figure 1. Configuration of sensing electrodes and outline of the proposed measurement system for body proximity and ECG monitoring.



(a) Body proximity measurement unit



(b) Cross-sectional equivalent circuit model of the body that coupled capacitively to the three electrodes

Figure 2. Schematics of (a) body proximity measurement unit and (b) cross-sectional equivalent circuit model of the body that coupled capacitively to the three electrodes.

electrodes were designed so as not to couple capacitively to the forearm and/or hand, which have almost the same biopotential with the brachium and shoulder. Detected ECG and body proximity signals were digitized by a commercial A/D converter (Biopac Systems, MP-150) at 1 kHz sampling with 16-bit resolution, and stored in a personal computer (PC).

## 2.1 Body proximity measurement

As shown in Figure 2(a), the unit of body proximity measurement consists of two measuring circuits for upper and lower body proximities respectively. The each circuit has identical configuration and is composed of an astable multivibrator circuit and a frequency-to-voltage (F/V) converter (National Semiconductor, LM231). The multivibrator includes series-connected two equivalent capacitors, which are formed by body, clothes, bed sheet and electrodes as can be seen in Figure 2(b). The multivibrator oscillates at a specific frequency depending on net capacitance of the two equivalent capacitors. The F/V converter outputs a DC voltage according to the oscillating frequency, i.e. to the net capacitance.

For the two series-connected equivalent capacitors incorporated in one multivibrator, given each coupling area between the body and the electrode is  $S$  [m<sup>2</sup>] and  $k_s S$  [m<sup>2</sup>], each coupling distance between them is  $d$  [m] and  $k_d d$  [m], and a common permittivity of the coupling

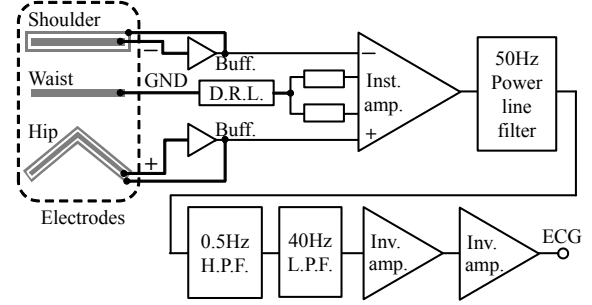

Figure 3. Block diagram of ECG measuring unit

clothes is  $\epsilon_c$ , the net capacitance  $C_{net}$  can be expressed by equation (1).

$$C_{net} = \epsilon_c \cdot \frac{k_s}{k_d + k_s} \cdot \frac{S}{d} \quad (1)$$

The oscillating frequency  $f_o$  [Hz] of the multivibrator is given by

$$f_o = \frac{k_v}{C_{net} R} \quad (2)$$

where  $R$  is resistance in Ohm in Figure 2(a) and  $k_v$  is a constant determined by power-supply voltage and threshold voltages of the Schmitt inverter IC (National Semiconductor, LM231) in Figure 2(a). Since output voltage  $V_{out}$  of the F/V converter is proportional to the input frequency  $f_o$ , relationship  $d$ ,  $S$  and  $V_{out}$  is expressed as follow:

$$V_{out} = k_f \cdot f_o = k_f k_v \left( \frac{k_d}{k_s} + 1 \right) \frac{1}{\epsilon_c R} \cdot \frac{d}{S} \quad (3)$$

where  $k_f$  is proportional factor determined by resistance and capacitance in the F/V converter circuit. Therefore, output of the measuring system,  $V_{outs}$  is proportional to the coupling distance and inversely proportional to the coupling area. This means that  $V_{out}$  becomes saturated at power-supply voltage when the body is out of the bed (i.e.  $S=0$ ,  $d=\infty$ ) and that  $V_{out}$  corresponding to supine position is smaller than that to lateral position due to smaller coupling area.

## 2.2 ECG measurement

The unit for ECG measurement consists of two buffers, an instrumentation amplifier, a power line filter, a band-pass filter and two inverting amplifiers (see Figure 3). Operational amplifier IC (Texas Instruments, OPA134) having high input-impedance (10 T $\Omega$  // 2 pF) was used for the buffer circuits to suppress voltage loss at each electrode coupled to the human body via cloth. Outputs of the buffers are respectively returned to a shielding part of the corresponding electrode as shown in Figure 4. A multilayered electrode similar to the present configuration is reported to reduce movement artifact when applied in

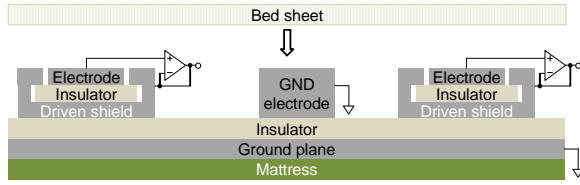

Figure 4. Cross-sectional scheme of layered electrode for ECG measurement.

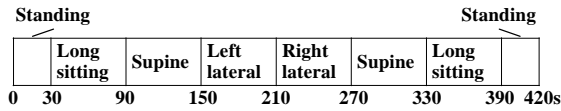

Figure 5. Experimental protocol for the simultaneous measurement of ECG and body proximities.

noncontact ECG measurement [5]. The driven-right-leg (DRL) technique [6] was introduced to improve signal-to-noise ratio (SNR). Total Gain of the amplifiers was set to 60 dB.

### 2.3 Simultaneous measurement of ECG and body proximities

The assembled electrodes and amplifiers were used to perform simultaneous measurements of ECG and proximities of upper and lower body. Six healthy males (ranging in age from 21 to 22 years) participated in this experiment. The study was approved by the Institutional Review Board of Tokyo Denki University. Prior to the experiment, the experimental protocols were explained to the subjects, who then provided written informed consent.

The subject wore a cotton pajamas 390  $\mu\text{m}$  thick before starting the measurement. Subjects were instructed to standing beside the bed, sit down on a bed, lie on the bed in a supine position, and change to a lateral position according to the protocol in Figure 5. ECG and proximities of upper and lower body were measured with the proposed system. As a reference signal, Lead III ECG was measured with a commercial biopotential amplifier (Teac, BA1104-CC) and with a commercial telemeter unit (Teac, TU-4). All ECGs and proximities were digitized at a sampling rate of 1 kHz by means of the commercial 16-bit A/D converter and stored in the PC. As another reference signal, a video sequence of the subject was also captured simultaneously by a webcam (BUFFALO, BSW13K06HSV) and stored in the same PC.

## 3. Results and discussion

As shown in Figure 6, both proximities of upper and lower body changed in a stepwise fashion in accordance with the change in the subject's position. In upper body

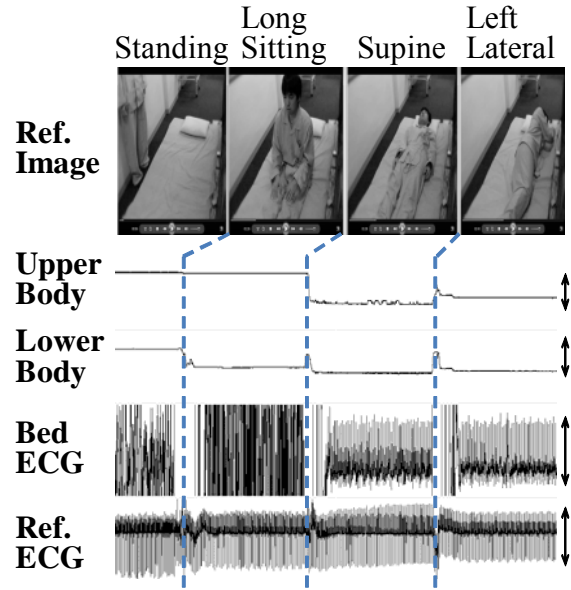

Figure 6. Simultaneously recorded signals of body proximities and ECGs (Subject #4).

proximity, there was no difference between “standing” and “long sitting” because no capacitive coupling was formed in both conditions. In contrast, proximity of lower body showed distinct difference between the two conditions. In lower body proximity, there were only subtle differences among conditions of “long sitting”, “supine” and “left lateral”. On the other hand, proximity of upper body indicated distinguishable voltages among them. Therefore combination of upper and lower proximities seemed beneficial for discriminating four conditions.

Figure 7 is two-dimensional plot of four conditions for six subjects. Each plot represents mean value of normalized proximities of upper and lower body at one of four conditions. All proximities were divided by the maximum voltage of each subject through conditions for the normalization. As can be seen in the figure, plots of the same condition are clustering, and four clusters corresponding to four conditions position apart in the two dimensional map. Though one subject in “long sitting” condition was placed close to cluster of “standing” condition, the four conditions can be distinguishable by the combination of upper and lower proximities regardless of individual variability.

In figure 6, ECG was not detected from the proposed system in “standing” and “long sitting” conditions. This is because no capacitive couplings were formed with upper body. Since proximities of upper and lower body can separate “standing” and “long sitting” conditions from the other conditions, combination of ECG with body proximities would be helpful for reducing false-alarm

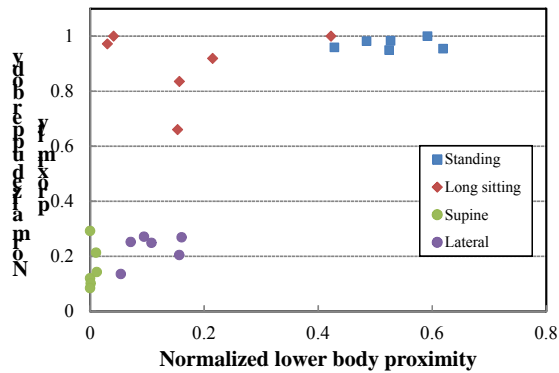

Figure 7. Two-dimensional plot of normalized proximities of upper and lower body in four conditions for six subjects.

probability, compared with a non-combined method.

On the other hand, ECG was successfully measured in “supine” and “left lateral” conditions, respectively (see Figure 6). In addition, so did in “right lateral” condition (data was not shown). As shown in Figure 8, not only QRS complex but also P-wave and T-wave were clearly visible, and these features of ECG were fully synchronized with that of reference ECG. Therefore ECG obtained by the proposed system would be beneficial for screening many sorts of arrhythmias. However, ECG obtained by the proposed system was considered inadequate for diagnosis which is based on waveform abnormality, because electrode positions in the proposed system are different from widely-known conventional positions. Furthermore, some distortions of the ECG waveform were observed in a number of subjects. These observations imply necessity for improving input impedance of the front-end buffer.

#### 4. Conclusion

We proposed a noncontact approach for continuous sensing of presence, position and ECG of a human body on a bed. Combination of two voltages, inversely proportional to the upper and lower body coupling capacitances, varied in accordance with the change in the subject’s position. In addition ECG was detected in the periods when the subject was in supine or lateral position. And distinct QRS complexes, P-waves and T-waves were confirmed, though some distortion can be observed. These results demonstrate the potential of the proposed approach for noncontact sensing of ECG and lying body proximities toward awareness-free pervasive and continuous monitoring.



Figure 8. Enlarged waveforms of simultaneously recorded ECGs in “supine” condition (Subject #4).

Future work to be addressed is improvement of input impedance of the front-end buffers to avoid waveform distortion. Fusion of two sets of electrodes is also necessary to achieve more simple system.

#### References

- [1] United Nations World Population Prospects: The 2012 Revision, <http://esa.un.org/wpp/index.htm>
- [2] Chi YM, Jung TP, Cauwenberghs G. Dry-contact and noncontact biopotential electrodes: Methodological review. *IEEE Reviews Biomed Eng* 2010;3:106-19.
- [3] Ueno A, Akabane Y, Kato T, Hoshino H, Kataoka S, Ishiyama Y. Capacitive sensing of electrocardiographic potential through cloth from the dorsal surface of the body in a supine position: A preliminary study. *IEEE Trans Biomed Eng* 2007;54:759-66.
- [4] Ueno A, Shiogai Y, Ishiyama Y. A primary study of indirect ECG monitor embedded in a bed for home health care. *IEEJ Trans Electro Informat Syst* 2007;127:1792-9.
- [5] Fukuyama Y, Suzuki R, Takayama S, Ueno A. Multi-layered fabric electrode for movement artifact reduction in capacitive ECG measurement. *Proc 35th Ann Int Conf IEEE EMBS* 2013:555-8.
- [6] Winter BB, Webster GJ. Driven-right-leg circuit design. *IEEE Trans Biomed Eng* 1983;30:62-66, 1983.

Address for correspondence.

Kei Ito  
 Senju Asahi-cho 5, Adachi-ku Tokyo 120-8551, Japan  
 uenolab\_mail@uenolab.jp